



ELECTRIC POWERED CARTS

OWNER'S MANUAL



HOG HAULER CART
Part No: 70220

97020-3

CONTENTS

CART FEATURES	3
FREQUENTLY ASKED QUESTIONS.....	4
CHARGING INFORMATION	5
OPERATING INSTRUCTIONS	6
TROUBLESHOOTING	8
BATTERY INFORMATION.....	9
WINCH BATTERY REPLACEMENT	10
DRIVETRAIN BATTERY REPLACEMENT.....	12
PARTS LISTING	14

OVERLAND CARTS GUARANTEE

 All Overland Carts are designed and assembled in the USA using parts made in-house along with quality global components.

 **Expect more. get more.**
FROM GRANITE INDUSTRIES

- Exceptional quality and service on every single product.
- Professional grade designs by our in-house engineers.
- Industry leading warranties.
- Owned and operated in the USA.

To view more products from Overland Carts scan the QR code with your phone or visit OverlandCarts.com



1 YEAR WARRANTY

- **Electronics:** Includes controller, s-drive, and wiring
- **Powertrain:** Includes transaxle containing the motor and differential
- **Wheels, Casters & Tires**
- **Batteries & Charger**
- **Hoppers:** Includes Brentwood hopper, and white garden hopper
- **Chassis:** Includes steel frame and powder coating

TERMS

Warranty starts from the delivery date of the cart.

We will repair, without charge, any defect due to faulty material or workmanship. These warranties do not cover failures due to abuse, misuse, improper installation, accidental damage or when repairs or modifications have been made or attempted to be made by anyone other than Granite Industries. Any defective products that meet warranty specifications and Granite Industries approval, may be returned to the factory to be repaired or replaced free of charge. (Granite Industries will pay to ship replacement item(s) to the customer; however the customer is responsible for shipment of products to the factory.)

This remedy is the sole remedy in contract, tort or otherwise, and Granite Industries is not liable for incidental, consequential or special damages.

These warranties give you specific legal rights, and you may have other rights which vary from state to state.

Should you have any questions, contact Granite Industries at 877-447-2648. (Proof of purchase may be required).

Overland Carts are covered by one or more of the following patents:

US D752,834 S	US D752,838 S	US D779,762 S
US D752,835 S	US D752,307 S	US D779,765 S
US D752,836 S	US D752,308 S	US D781,020 S
US D752,837 S		

Overland carts are a part of the Granite Industries family. All carts are manufactured by Granite Industries in Archbold, Ohio.



Customer Service
877-447-2648
M-F, 8am - 5pm EST

CART FEATURES

Built with you in mind.

Our carts come fully assembled

All Overland Carts come fully assembled, charged and ready to use. All you have to do is power the cart on and drive away. (We do recommend charging overnight after receiving.)

Crate Disassembly Instructions:

We recommend using a drill or an electric screwdriver with a #2 Phillips bit or a #2 square bit to remove the screws.

We recommend using a hammer or crowbar to remove the portions that are nailed down.

We designed our carts to be simple to operate:

- To turn on, pull the red On/Off switch out towards you.
- Toggle the black switch for forward and reverse.
- Grasp and twist the throttle.
- To turn the cart off, simply push the red button in.

Safety Features

- **Emergency Stop** – The red E-Stop button allows the user to immediately stop the progress of the cart.
- **AutoLock** – Automatically locks the wheels when the throttle is not being applied. This feature prevents the cart from rolling away from the user and also provides easy loading and unloading on inclines.
- **HillSense** – Allows the cart to be used safely on inclines and declines. The cart will travel at the speed set by the user, not by the incline or decline.
- **SmoothStart** – On acceleration, power is applied to the drive tires in a controlled manner ensuring a smooth start each time.
- **Four Wheel Design** – All Overland Carts have at least four wheels to provide maximum stability.

They've been tested (again and again)

The standard 24 amp-hr rechargeable battery packs have been extensively tested. We are confident to rate the batteries with a 6-8 hour real world capacity.



Satisfaction Guaranteed

Granite Industries is committed to making sure each Overland Cart meets your expectations. To ensure customer satisfaction, we offer a 15 day money back guarantee. Use the cart and see how much easier the cart makes your projects. If you're not satisfied, simply contact Granite Industries at 877-447-2648 for a return authorization and details.

Orders and quote requests can be emailed to support@graniteind.com or faxed to 419-445-3304

FREQUENTLY ASKED QUESTIONS

How long do the batteries last on a single charge?

It is completely dependent upon how much weight is being carried, the type of terrain, and the softness or hardness of the surface. We estimate a range of 6-8 hours of "real world" use. PLEASE NOTE: Most use is not as intense as our "real world" estimates, so actual use time is typically much longer. Visit [YouTube.com/OverlandCarts](https://www.youtube.com/OverlandCarts) to view videos of our product testing.

When and how long should I charge my cart?

Charge your cart immediately after using. If, during operation, the battery indicator light goes to red, it is time to recharge. It is recommended to leave the cart on the charger overnight to extend the life of the batteries.

How long will the batteries last before needing to be replaced?

The batteries are designed to last for 300-500 charge/discharge cycles, which translate into approximately 1-2 years. The batteries are common, and can be purchased from Granite, your local battery supplier, or on Amazon.

Will tipping the unit hurt the batteries, electronics, or drive system?

No. Batteries, electronics, and drives can operate in any orientation.

What is the maximum speed?

All Overland Carts operate from 0 to 3.5 miles per hour in both forward and reverse.

While pushing my cart in manual/freewheel mode, it suddenly decelerates aggressively. What causes this?

There is a safety feature on your Overland Cart that is designed to prevent the cart from running away when the brake is manually disengaged.

How much weight can my cart handle?

750 lbs is the maximum load for level ground.

Why does my cart lose traction when one wheel is off the ground?

The drive system is an open differential that allows the machine to efficiently make turns without skidding the tires. The drawback is that if one of the drive tires leaves the ground, it will simply spin until all tires are back on the ground.

Is a balanced load important to the performance?

Yes. Balancing the load so that it is not top-heavy or side-loaded, will allow much safer operation. Furthermore, most of the load should be located over top of the drive wheels for better traction.

How do I clean my Overland Cart?

Simply remove all debris, hose it down with soapy water, and towel dry. We do not recommend using a pressure washer.

Can I use my Overland Cart in cold temperatures?

You certainly can, but we recommend that you charge and store the batteries at room temperature.

What maintenance is required?

Not much, really! Simply remember to always recharge when not in use - it's okay to leave the cart on the charger. The drive system is sealed for life, thus no lubrication is required. Also, keep the unit dry to enhance its life and appearance.

How should I store my cart?

We recommend keeping your cart indoors, out of the rain and other elements. For long-term, or "off season" storage, give the battery an overnight charge, then disconnect the battery pack from the cart and store it indoors at room temperature. Every 3-4 months, fully charge the battery even though it's not in use. This helps to prolong the life of the batteries.

Where is the serial number?

Every Overland Cart comes with its own serial number. This is located on the front side of the upper control box. You will need this number when you fill out your warranty card.

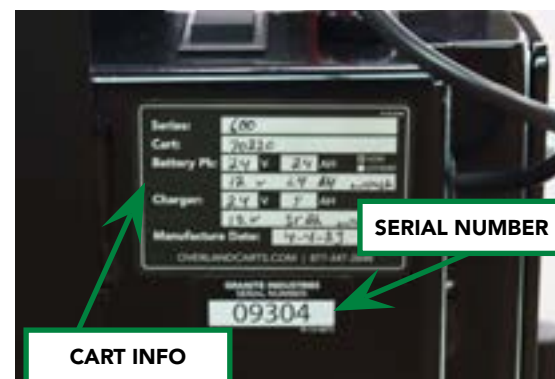

FREQUENTLY ASKED QUESTIONS

How do I identify the right and left tires?

Our ag tires have a specific tread pattern and if you ever need to replace a tire, you need to identify them as right or left. To do so, stand in front of your cart, so you are looking at the hopper. The left tire will be on your left side.



CHARGING INFORMATION

CHARGE YOUR CART

When your cart arrives, please plug it in and make sure the battery is fully charged. There is a battery charge display on the side of the battery pack.

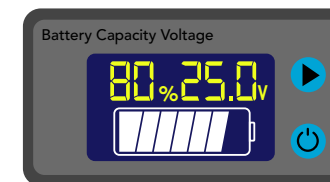

The charger can be left connected to the batteries after a full charge (green light) without harming the batteries. It uses a three stage charging system to optimize battery longevity. The charger uses minimum power in standby mode and maintains the batteries at full charge.

For the best battery life, charge the cart after each use or at the end of the work day. It's preferable to let the batteries charge overnight by plugging the cart into a 110V outlet.

Capacity	Single 12V AGM Battery	24V AGM Battery Pack (Two 12V Batteries in series)
100% Floating Charge (when plugged in)	13.00V+	26.00V+
100%	13.00V	26.00V
90%	12.75V	25.50V
80%	12.50V	25.00V
70%	12.30V	24.60V
60%	12.15V	24.30V
50%	12.05V	24.10V
40% *Recharge Batteries*	11.95V	23.90V
30%	11.81V	23.62V
20%	11.66V	23.32V
10%	11.51V	23.02V
0%	10.5V	21.00V
1%	10.80V	21.60V
0%	9.50V	19.00V

BATTERY CAUTIONS AND WARNINGS

1. Before using the battery charger, read all instructions and cautionary markings on the battery charger, batteries and the product using the batteries.
2. Only use the type of batteries that the charger is specified for. Other types of batteries may burst, causing personal injury or damage.
3. Do not expose charger to rain or snow.
4. Do not cover the charger or charge battery in an airtight enclosure. Ventilation is important to prevent overheating.
5. Make sure extension cord is not used unless absolutely necessary. Use of improper extension cord could result in

risk of fire and electric shock. If extension cord must be used, make sure:

- The pins on the plug of the extension cord are the same number, size and shape as those on the charger. (3 prong with ground)
 - The extension cord is properly wired and in good electrical condition. A 16 ga cord or heavier duty extension cord is recommended.
6. Do not operate a charger that has been dropped, damaged or has a damaged cord or plug - replace immediately if there are signs of damage!
 7. Do not disassemble the charger.

OPERATING INSTRUCTIONS

SAFETY INFORMATION

- Flat free semi pneumatic tires are not pressurized and do not have a valve stem.
- Only use chargers and batteries issued by Overland Carts. Use of third party batteries or chargers may cause harm to the user and the cart.
- Always make sure the attachments are latched securely before operating the cart.
- Always make sure the load is distributed evenly and the cart is stable before operating.
- Push in the red E-Stop whenever the cart is sitting still or whenever the batteries are charging.
- Do not exceed the rated capacity of 750 pounds for the cart on flat surfaces.
- Exercise caution when operating on inclines or declines.
- Do not drive the cart over sudden drops such as curbs, steps, or ledges. We recommend using ramps to navigate uneven surfaces.
- The metal battery pack can be opened to reveal the batteries; however, the physical batteries should never be opened. They are sealed lead acid batteries and cannot be resealed. Do not attempt to add more battery acid or water. If the batteries need replaced, please purchase new batteries.

BEST PRACTICES

- Hand wash your Overland Cart with soapy water. Never use a pressure washer.
- Do not drive your cart through deep puddles of water and do not submerge the drive system or battery box.
- The drive system is lubricated for life, so no maintenance is required.
- When the battery indicator light goes to red, it is time to recharge.
- Recharge cart immediately after using.

POWER YOUR CART ON

To power your cart on, pull the red E-stop button out. You will notice the battery indicator lights light up, and your cart is ready for operation.

If the Overland Cart sits inactive for 20 minutes while on, it will go to sleep in order to conserve power. To wake the cart up, push the E-Stop button in, and pull it back out to power your cart on again.

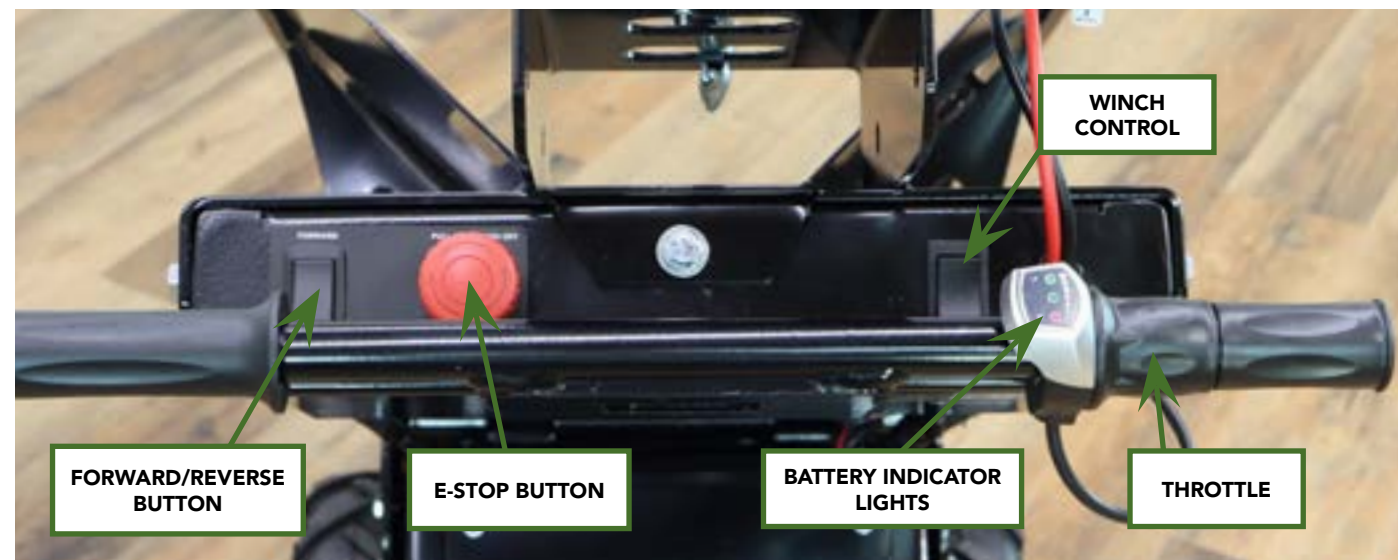

OPERATING INSTRUCTIONS

DRIVING YOUR CART

Once your cart is on, make sure your forward/reverse button is toggled upwards for forward. Twist the throttle towards you and the cart will begin moving forward. While driving your Overland Cart forward, stay directly behind the cart with both hands on the handles. When operating the cart in reverse, do NOT stand in the path of the cart and walk backwards. Instead, turn around and stand beside the unit to prevent accidental injury.



FORWARD OPERATION

REVERSE OPERATION

SLOPES AND INCLINES

When going downhill, operate your cart in reverse, leading the cart downhill with the handles first. This will prevent your cart from tipping over, especially if it is carrying a full load. Do not drive your cart across an incline, this may cause the cart to roll over on it's side. Always travel parallel with the slope or incline.

FREE WHEEL MODE

The drive system is equipped with a lever that overrides the electromechanical brake for manually operating your Overland Cart. The brake lever allows you to override the electric brake when you need to push the cart manually, when loss of power had occurred. With the brake in the disengaged position, the E-Stop button must be pushed in, and the power turned off, or the drive system will not move freely. The controller will NOT operate the motor when the brake is disengaged.

When lever is in the down position the brake is engaged, and when up it is disengaged. When you reset the brake system the unit will not operate until you toggle the power button off and back on, this process will need to be repeated every time the brake is manually disengaged.

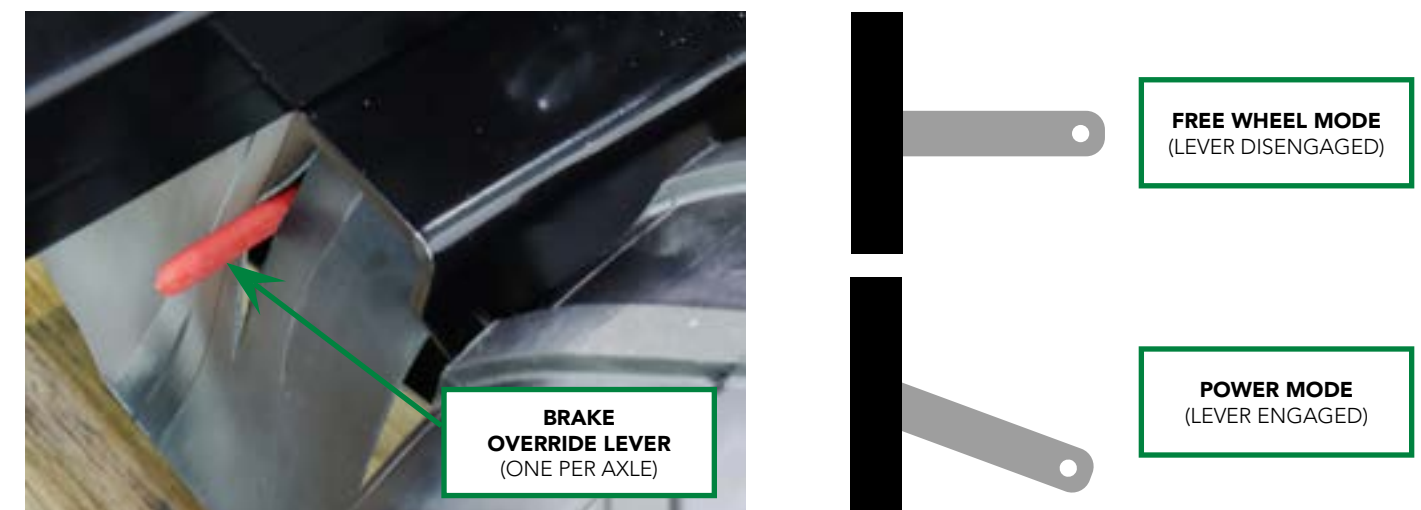

TROUBLESHOOTING

Issue	Possible Problem	Solution
Cart will not run	Batteries are dead	Charge the Overland Cart
	E-Stop is in the OFF position	Pull e-stop out, to the ON position
	Unit is in sleep mode	Cycle the unit OFF for a couple seconds, then back ON
	Cart is in freewheel mode (brake is disengaged)	Re-engage motor brake (see free wheel mode section)
	Electrical malfunction	Disconnect and connect all electrical connections, and make sure they are all secure
	Moisture issue	Let dry, avoid getting the s-drive and battery box wet
Cart shuts off during use	Circuit breaker has tripped	Push the reset button on the battery pack (see diagram below).
	Thermal overload (weight, climb angle, or terrain may have exceeded transaxle capacity)	Release throttle, allow transaxle to cool down at least 30 seconds. Unload some weight, cycle power switch and operate machine again. Reset button will likely need to be pushed.
Cart suddenly stops	Broken or loose motor wire or connector	Check motor wires and brake wires to make sure none are broken, and also check connector to make sure wires are secure
Cart abruptly slows down while in freewheel mode	Safety feature has triggered preventing the cart from rolling away	Push the cart slower while in freewheel mode
Batteries are not lasting as long as desired	Cold batteries	Keep batteries warm
	Batteries not fully charged	Make sure your cart is fully charged before using
	Batteries are damaged or too old	Replace your batteries
	Loose wire connections	Check all connections to make sure everything is secure
Charger light goes directly to green when charging, but battery is not charged	The battery and/or charger may have gone bad	Test the charger on another battery if possible. Replace battery and/or charger
	The connections may have come loose, or disconnected	Check charger and battery connections

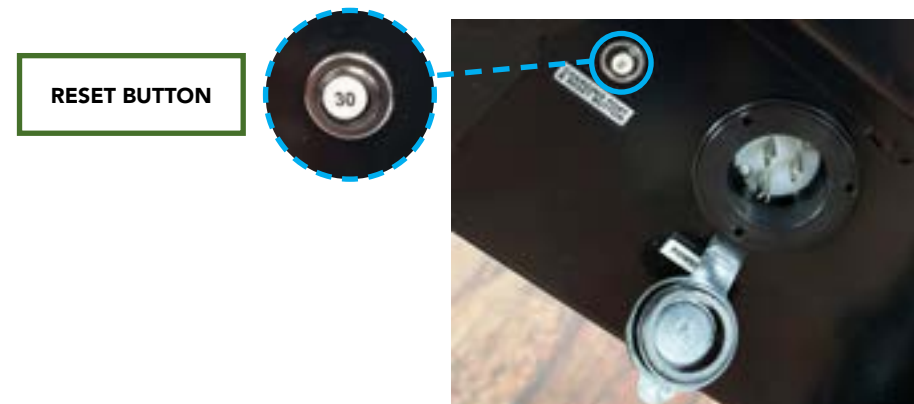

BATTERY INFORMATION

IMPORTANT RECOMMENDATIONS

- It is recommended to wear insulated gloves when handling batteries.
- If equipment is to be stored for a long period of time, the batteries should be disconnected to avoid undue drain.
- When replacing your batteries, fasten them tightly, but do not apply undue force to the terminals, or bend them.
- Do not place batteries in close proximity to objects which can produce sparks or flames.
- Avoid exposing batteries to heat.
- Do not mix batteries with different capacities, different ages or different makes.
- For best results and generally acceptable performance and longevity, keep operating temperature range between 5° F (-15° C) and 122° F (50° C)
- It is good practice to ensure that the connections are re-torqued and the batteries are cleaned periodically.
- Do not attempt to disassemble batteries. Contact with sulfuric acid may cause harm. If it should occur, wash skin and clothing with liberal amounts of water.
- Batteries should not be stored in a discharged state or at elevated temperatures.
- Please recycle old batteries. Do not throw them away, or attempt to burn them. Attempting to burn batteries (new or old) may cause them rupture or explode.

BATTERY FEATURES

- Absorbent Glass Mat (AGM) technology for superior performance.
 - AGM design ensures the acid inside the battery is spill-proof
 - Vibration resistant
 - Better performance in cold temperatures
 - Faster charging
 - Longer expected life
- Valve regulated, spill proof construction allows safe operation in any position. However upside down is not recommended.
- Maintenance free design. There is no need to add electrolyte, as gases generated during the charge phase are recombined in a unique oxygen cycle.
- Power/volume ratio yielding unrivaled energy density.
- Special separators, advanced plate composition and a carefully balanced electrolyte system ensure the battery has the ability to recover from an excessively deep discharge.
- All batteries feature a series of low pressure, one-way relief valves. These valves safety release any excessive accumulation of gas inside the battery and then reseal themselves.
- Batteries may be discharged over a temperature range of 5° F (-15° C) and 122° F (50° C), and charged at temperatures ranging from -5° F (-15° C) and 104° F (40° C). For best results we recommend charging the batteries at room temperature.
- The case materials impart great resistance to shock, vibration, chemicals and heat.
- U.L. recognized under file number MH 14533.
- ISO 9001/14001/18001 Certified

WINCH BATTERY REPLACEMENT (12v, 24 amp)

TOOLS

#1 or #2 Phillips Screwdriver



1 Remove the four screws and washers from the battery box.



2 You will notice one 12v, 24ah battery and a charger inside of the box. This battery supplies power for the winch only.



3 Pull the battery out, loosen the screws and disconnect the wiring from the battery.

WINCH BATTERY REPLACEMENT (12v, 24 amp)

4 Reconnect the wires to the battery as shown below. Place the battery, charger and wires back into the box. Secure the lid in place with the 4 screws and washers you removed in step 3.

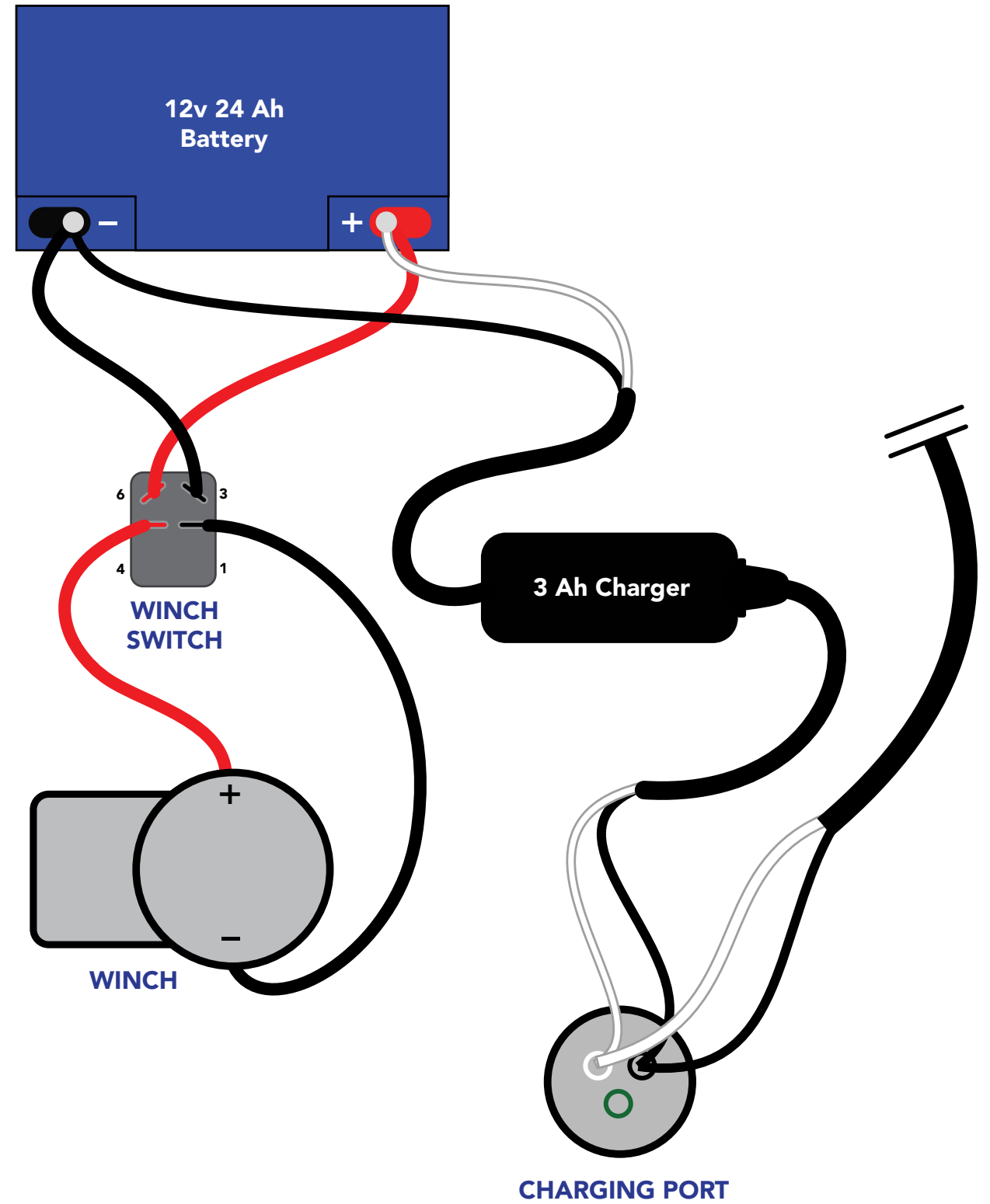

DRIVETRAIN BATTERY REPLACEMENT (24v, 24 amp)

TOOLS

#1 or #2 Phillips Screwdriver



1 Remove the pin from the rod holding the hog channel in place.



2 Lift the hog channel off of the cart and set aside. Doing so will expose the battery box for the cart.



3 Remove the 4 screws holding the battery box cover in place.

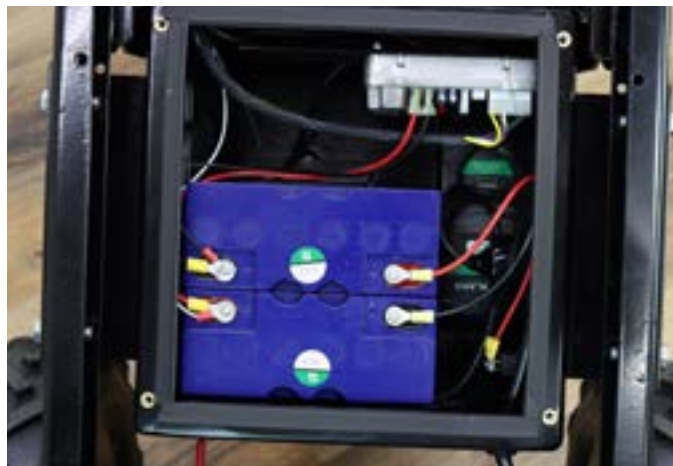

4 Disconnect the wires from the battery packs. Remove the old batteries.

DRIVETRAIN BATTERY REPLACEMENT (24v, 24 amp)

4

Install the new batteries. Use the diagram below to reconnect the wires to the battery.

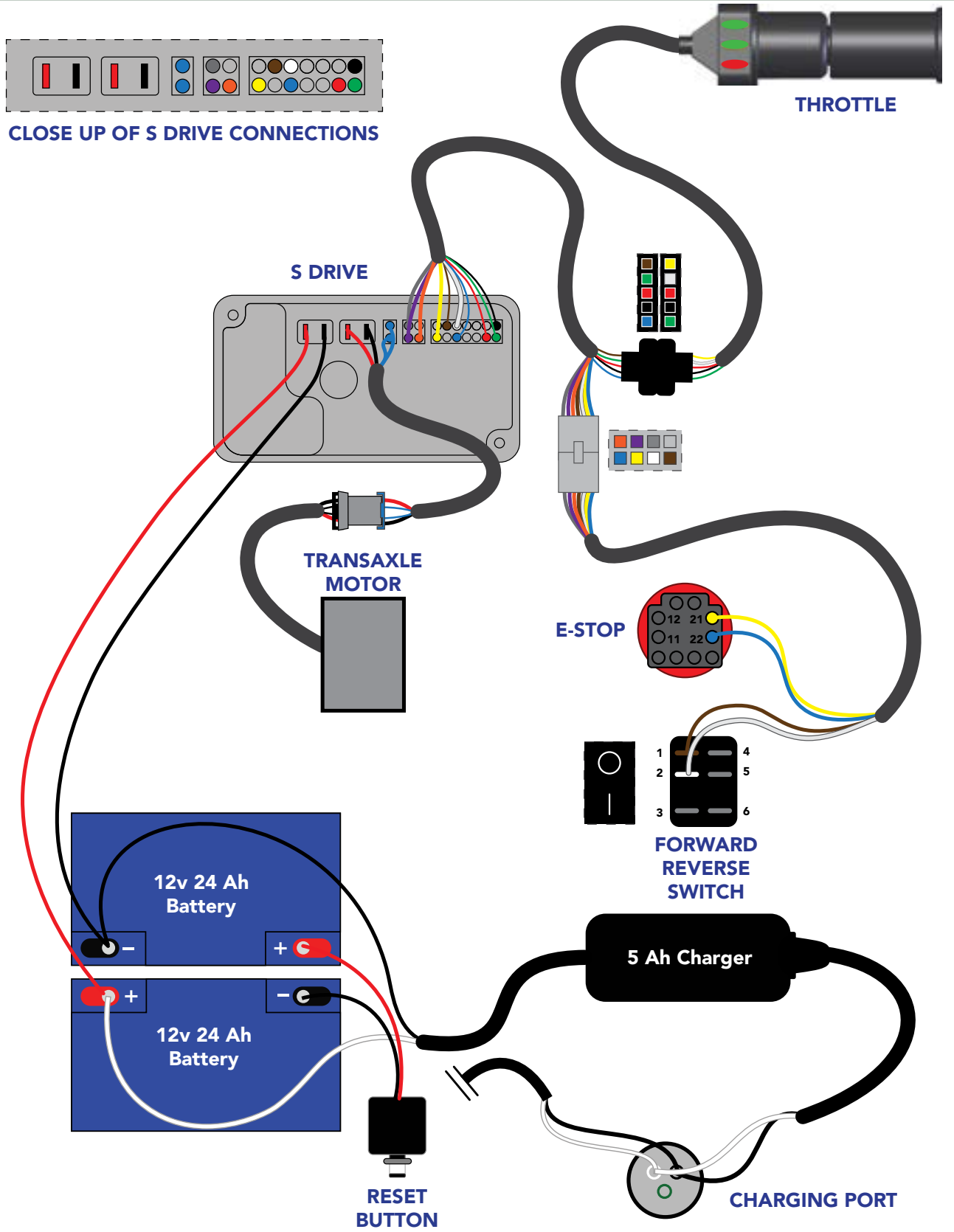
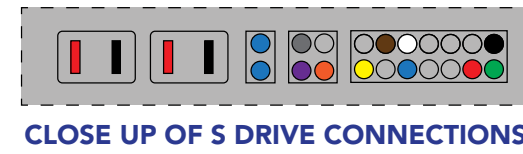

DRIVETRAIN BATTERY REPLACEMENT (24v, 24 amp)



6 Reinstall the hog channel. Secure in place with the rod and pin

PARTS LIST

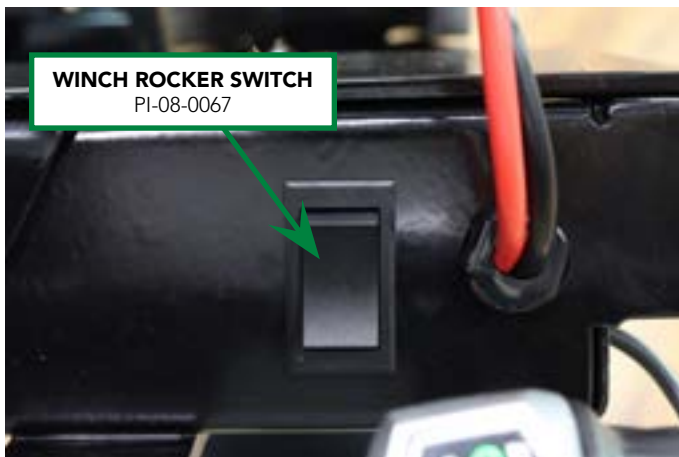
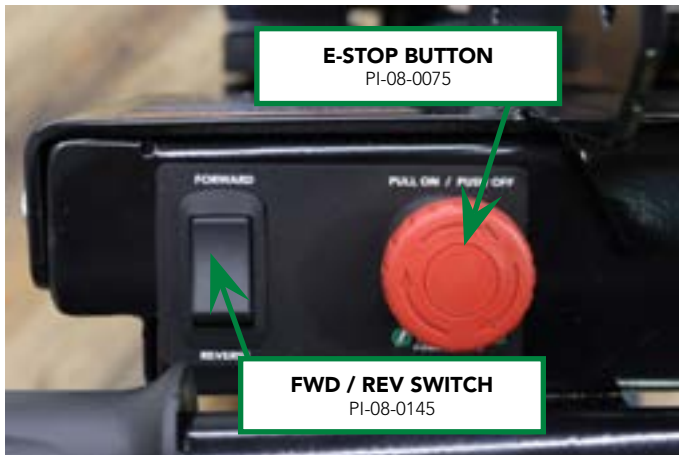

PARTS LIST





Throttle Kit
PI-08-0053



Fwd / Rev Switch
PI-08-0145



E-Stop Switch
PI-08-0075



600W Transaxle
PI-08-0146



24V 5A AGM Charger
PI-11-0191



3 Amp Charger for Winch
PI-11-0173



S-Drive 90
PI-08-0189



13" Flat Free Dual Ag
PI-06-0182 (Left)
PI-06-0183 (Right)



10" Swivel Caster
PI-06-0055



30A Replacement Breaker
PI-08-0045



Winch
PI-11-0232



12V 24A AGM Battery
PI-11-0215

Part No	Description	Weight	Dimensions
PI-08-0053	Throttle Kit	8 oz	4' cord
PI-08-0145	Forward/Reverse Switch	1 oz	1.75"H x 2"W x 1"W
PI-08-0075	E-Stop Switch	2 oz	1.5"H x 3"W x 1.5"D
PI-08-0146	24V 600W Transaxle	16 lb	7"H x 5"W x 23"D
PI-11-0191	24V 5A AGM Charger	2 lb	10' Cord
PI-11-0173	12V 3AH AGM Battery Charger for Winch	2 lb	10' cord
PI-11-0189	S Drive 90	1 lb	1.5"H x 5"L x 3"D
PI-06-0182	13" Left Flat Free Single Ag Tire - 3/4" Black Hub*	30 lb	13" Diameter - 8"W
PI-06-0183	13" Right Flat Free Single Ag Tire - 3/4" Black Hub*	30 lb	13" Diameter - 8"W
PI-06-0055	Rear Swivel Caster with 10" Flat Free Tire	10 lb	10" Diameter - 3"W
PI-08-0145	30A Replacement Breaker	3 oz	3"H x 1.5"W x 2"D
PI-11-0232	2000 lb winch with 49' cable	12 lb	4"H x 11"W x 4"D
PI-11-0215	12v 24A AGM Battery	13 lb	6.5"H x 7"W x 3"D

*When looking from the front of the cart



All Overland Carts are manufactured by:

Granite Industries
595 East Lugbill Rd.
Archbold, Ohio 43502

877-447-2648
OverlandCarts.com | Granitelnd.com